11.3 Gbps Laser Diode Driver

FEATURES

- Up to 11.3 Gbps Operation
- Two-Wire Digital Interface
- Digitally Selectable Modulation Current up to 80 mA
- Digitally Selectable Bias Current up to 100 mA Source or Sink
- Automatic Power Control (APC) Loop
- Supports Transceiver Management System (TMS)
- Programmable Input Equalizer
- Cross-point Control
- Includes Laser Safety Features
- Adjustable Coupling Ratio

- Single +3.3 V Supply
- Case Temperature -25°C to 100°C
- Small Surface Mount Footprint $4\text{mm} \times 4\text{mm}$ 24-Pin, RoHS-compliant QFN Package

APPLICATIONS

- 10 Gigabit Ethernet Optical Transmitters
- 8x and 10x Fibre Channel Optical Transmitters
- SONET OC-192/SDH STM-64 Optical Transmitters
- XFP and SFP+ Transceiver Modules
- XENPAK, XPAK, X2 and 300-pin MSA Transponder Modules

DESCRIPTION

The ONET1101L is a high-speed, 3.3-V laser driver designed to directly modulate a laser at data rates from 2 Gbps to 11.3 Gbps.

The device provides a two-wire serial interface that helps digital control of the modulation, plus bias currents and cross point, eliminating the need for external components. An optional input equalizer can be used for equalization of up to 300 mm (12") of microstrip or stripline transmission line on FR4 printed circuit boards.

The ONET1101L includes an integrated automatic power control (APC) loop, plus circuitry to support laser safety and transceiver management systems.

The laser driver is characterized for operation from -25°C to 100°C case temperature and is available in a small footprint using a $4\text{mm} \times 4\text{mm}$, 24-pin RoHS-compliant QFN package.



Please be aware that an important notice concerning availability, standard warranty, and use in critical applications of Texas Instruments semiconductor products and disclaimers thereto appears at the end of this data sheet.



These devices have limited built-in ESD protection. The leads should be shorted together or the device placed in conductive foam during storage or handling to prevent electrostatic damage to the MOS gates.

BLOCK DIAGRAM

Figure 1 shows a block diagram of the ONET1101L device. The laser driver consists of an equalizer, a limiter, an output driver, DC offset cancellation with cross point control, power-on reset circuitry, a 2-wire serial interface (including a control logic block and modulation current generator), a bias current generator and automatic power control loop, and an analog reference block.

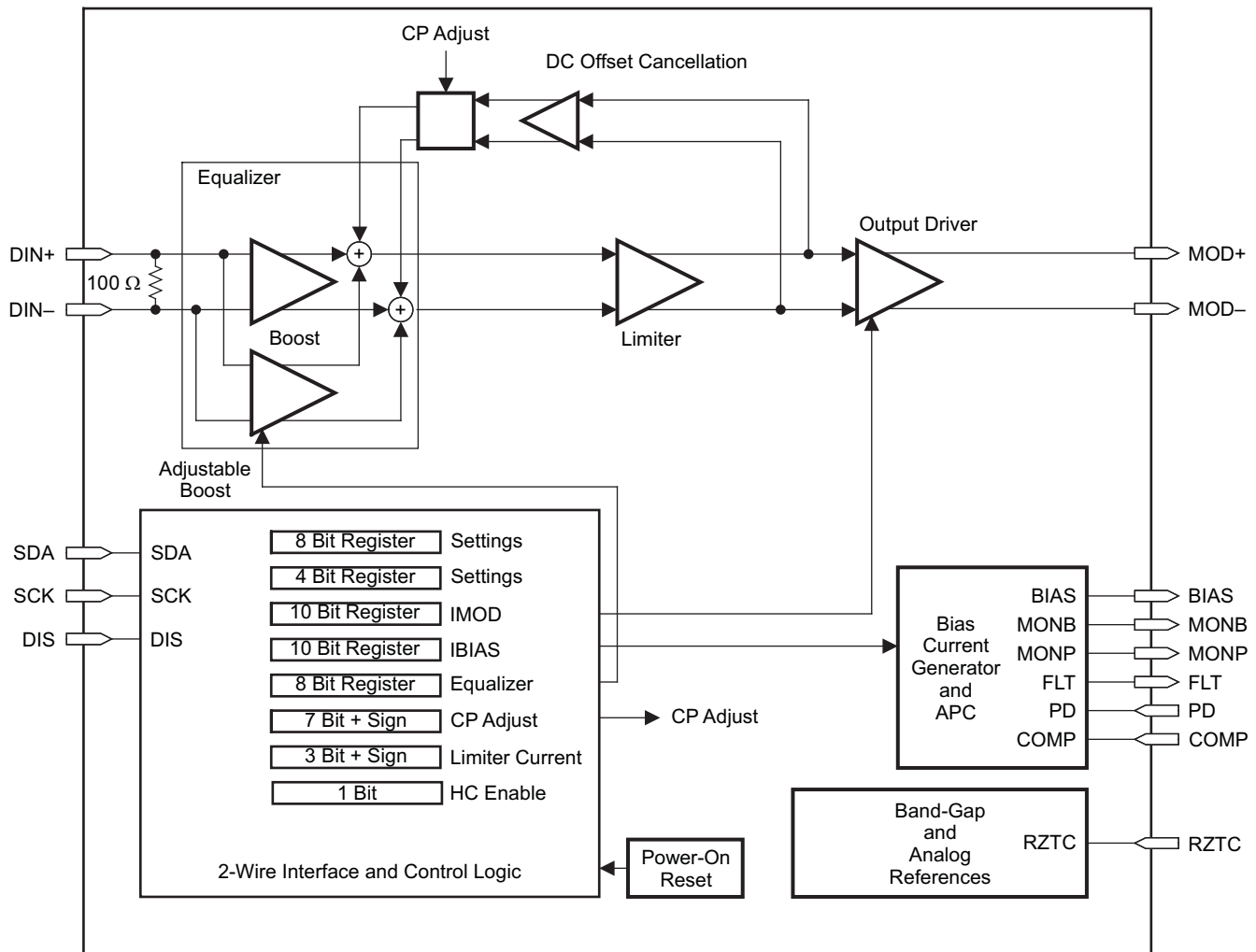

B0285-01

Figure 1. Block Diagram of the ONET1101L

PACKAGE

The ONET1101L is packaged in a small footprint $4\text{mm} \times 4\text{mm}$ 24-pin, RoHS-compliant QFN package, with a lead pitch of 0.5 mm. The 24-pin QFN Package top view and pin description follow.

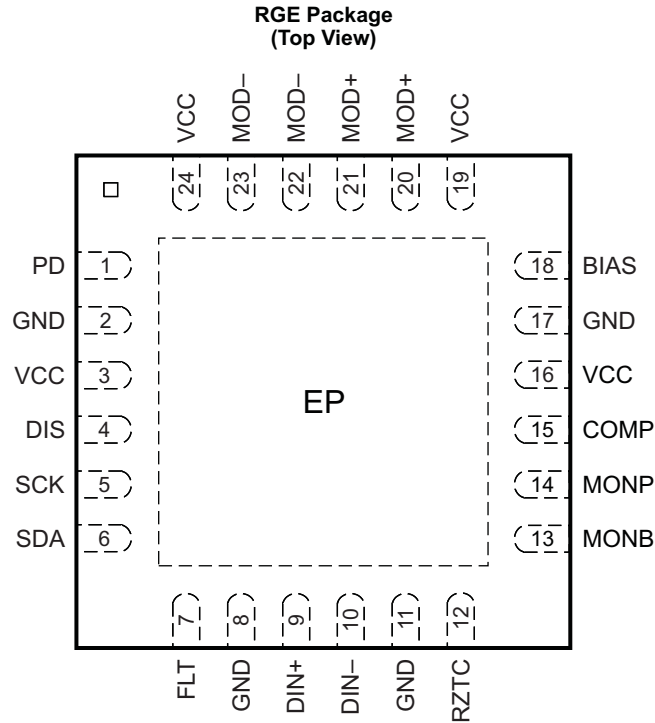

P0024-07

24-Pin QFN Package, 4mm × 4mm (Top View)

PIN DESCRIPTION

PIN	NAME	TYPE	DESCRIPTION
1	PD	Analog	Photodiode input. Pin can source or sink current dependent on register setting.
2, 8, 11, 17, EP	GND	Supply	Circuit ground. Exposed die pad (EP) must be grounded.
3, 16, 19, 24	VCC	Supply	3.3 V ± 10% supply voltage
4	DIS	Digital-in	Disables the bias and modulation currents when set to high state. Toggle to reset a fault condition.
5	SCK	Digital-in	2-wire interface serial clock. Connect a pull-up resistor (10 kΩ typical) to VCC.
6	SDA	Digital-in	2-wire interface serial data input. Connect a pull-up resistor (10 kΩ typical) to VCC.
7	FLT	Digital-out	Fault detection flag.
9	DIN+	Analog-in	Non-inverted data input. On-chip differentially 100 Ω terminated to DIN-. Must be AC coupled.
10	DIN-	Analog-in	Inverted data input. On-chip differentially 100 Ω terminated to DIN+. Must be AC coupled.
12	RZTC	Analog	Connect external zero TC 28.7 kΩ resistor to ground (GND). Used to generate a defined zero TC reference current for internal DACs.
13	MONB	Analog-out	Bias current monitor. Supplies a 1% replica of the bias current. Connect an external resistor to ground (GND). If the voltage at this pin exceeds 1.16 V, a fault is triggered. Choose a resistor that yields a MONB voltage of 0.8 V at the maximum desired bias current.
14	MONP	Analog-out	Photodiode current monitor. Supplies a 12.5% replica of the photodiode current when PDRNG = 1X, a 25% replica when PDRNG = 01 and a 50% replica when PDRNG = 00. Connect an external resistor (5 kΩ typical) to ground (GND).
15	COMP	Analog	Compensation pin used to control the bandwidth of the automatic power control (APC) loop. Connect a 0.01 μF capacitor to ground.
18	BIAS	Analog	Sinks or sources average bias current for laser in both APC and open loop modes.
20, 21	MOD+	CML-out	Non-inverted modulation current output. IMOD flows into this pin when input data is high (current).
22, 23	MOD-	CML-out	Inverted modulation current output. IMOD flows into this pin when input data is low (current).

ABSOLUTE MAXIMUM RATINGS⁽¹⁾

over operating free-air temperature range (unless otherwise noted)

		VALUE	UNIT
V _{CC}	Supply voltage ⁽²⁾	–0.3 to 4.0	V
V _{DIS} , V _{RZTC} , V _{SCK} , V _{SDA} , V _{FLT} , V _{MONB} , V _{MONP} , V _{COMP} , V _{PD} , V _{BIAS}	Voltage at DIS, RZTC, SCK, SDA, DIN+, DIN–, FLT, MONB, MONP, COMP, PD, BIAS, MOD+, MOD– ⁽²⁾	–0.3 to 4.0	V
IDIN–, IDIN+	Maximum current at input pins	25	mA
IMOD+, IMOD–	Maximum current at output pins	120	mA
ESD	ESD rating at all pins	2	kV (HBM)
T _{J,max}	Maximum junction temperature	125	°C
T _{STG}	Storage temperature range	–65 to 150	°C
T _C	Case Temperature	–40 to 110	°C

- (1) Stresses beyond those listed under *absolute maximum ratings* may cause permanent damage to the device. These are stress ratings only, and functional operation of the device at these or any other conditions beyond those indicated under *recommended operating conditions* is not implied. Device exposure to conditions outside the Absolute Maximum Ratings ranges for an extended duration can affect device reliability.
- (2) All voltage values are with respect to network ground terminal.

RECOMMENDED OPERATING CONDITIONS

over operating free-air temperature range (unless otherwise noted)

		MIN	NOM	MAX	UNIT
V _{CC}	Supply voltage	2.97	3.3	3.63	V
V _{IH}	Digital input high voltage	DIS, SCK, SDA			V
V _{IL}	Digital input low voltage	DIS, SCK, SDA			V
	Photodiode current range	Control bit PDRNG = 1X, step size = 3 μA			μA
		Control bit PDRNG = 01, step size = 1.5 μA			
		Control bit PDRNG = 00, step size = 0.75 μA			
R _{RZTC}	Zero TC resistor value ⁽¹⁾	28.4	28.7	29	kΩ
V _{IN}	Differential input voltage swing	EQENA = 0			mV _{p-p}
t _{R-IN}	Input rise time	20% to 80%			ps
t _{F-IN}	Input fall time	20% to 80%			ps
T _C	Case Temperature	–25		100	°C

- (1) Changing the value alters the DAC ranges.

DC ELECTRICAL CHARACTERISTICS

Over recommended operating conditions with a 25 Ω output load, open loop operation, $I_{MOD} = 40$ mA, $I_{BIAS} = 40$ mA, and $R_{RZTC} = 28.7$ k Ω (unless otherwise noted)

PARAMETER	TEST CONDITIONS	MIN	TYP	MAX	UNIT		
V_{CC}	Supply voltage	2.97	3.3	3.63	V		
I_{VCC}	Supply current	$I_{MOD} = 40$ mA, $I_{BIAS} = 40$ mA, excluding I_{MOD} and I_{BIAS} , EQENA = 0		66	85	mA	
		$I_{MOD} = 80$ mA, $I_{BIAS} = 80$ mA, excluding I_{MOD} and I_{BIAS} , EQENA = 0		95	118		
		$I_{MOD} = 40$ mA, $I_{BIAS} = 40$ mA, excluding I_{MOD} and I_{BIAS} , EQENA = 1		73	95		
		Output off (DIS = HIGH), $I_{MOD} = 40$ mA, $I_{BIAS} = 40$ mA, EQENA = 0		42			
R_{IN}	Data input resistance	Differential between DIN+ / DIN–		80	100	120	Ω
	Digital input current	SCK, SDA, pull up to VCC		–10	10		μ A
		DIS, pull down to GND		–10	10		μ A
V_{OH}	Digital output high voltage	FLT, pull-up to VCC, $I_{SOURCE} = 50$ μ A		2.4		V	
V_{OL}	Digital output low voltage	FLT, pull-up to VCC, $I_{SINK} = 350$ μ A		0.4		V	
$I_{BIAS-MIN}$	Minimum bias current	See table note ⁽¹⁾		5		mA	
$I_{BIAS-MAX}$	Maximum bias current	Sink, BIASPOL = 0 DAC set to maximum, open and closed loop		85	100		mA
		Source, BIASPOL = 1 DAC set to maximum, open and closed loop		80	100		
$I_{BIAS-DIS}$	Bias current during disable			100		μ A	
	Bias pin compliance voltage	BIASPOL = 0		0.8		V	
		BIASPOL = 1		$V_{CC} - 0.8$			
V_{PD}	Photodiode reverse bias voltage	APC active, $I_{PD} = \text{max}$		1.3	2.3		V
	Photodiode fault current level	Percent of target I_{PD} ⁽²⁾		150%			
	Photodiode current monitor ratio	I_{MONP} / I_{PD} with control bit PDRNG = 1X		10%	12.5%	15%	
		I_{MONP} / I_{PD} with control bit PDRNG = 01		20%	25%	30%	
		I_{MONP} / I_{PD} with control bit PDRNG = 00		40%	50%	60%	
	Bias current monitor ratio	I_{MONB} / I_{BIAS} (nominal 1/100 = 1%)		0.9%	1.0%	1.2%	
V_{CC-RST}	V_{CC} reset threshold voltage	V_{CC} voltage level which triggers power-on reset		2.5		2.8	V
$V_{CC-RSTHYS}$	V_{CC} reset threshold voltage	Hysteresis		100		mV	
$V_{MONB-FLT}$	Fault voltage at MONB	Fault occurs if voltage at MONB exceeds value		1.1	1.16	1.22	V

- (1) The bias current can be set below the specified minimum according to the corresponding register setting; however in closed loop operation settings below the specified value the bias current can trigger a fault.
- (2) Assured by simulation over process, supply, and temperature variation.

AC ELECTRICAL CHARACTERISTICS

Over recommended operating conditions with 25 Ω output load, open loop operation, $I_{MOD} = 40$ mA, $I_{BIAS} = 40$ mA, and $R_{RZTC} = 28.7$ k Ω . Typical operating condition is at $V_{CC} = 3.3$ V and $T_A = 25^\circ\text{C}$ (unless otherwise noted)

PARAMETER		TEST CONDITIONS	MIN	TYP	MAX	UNIT
SDD11	Differential input return gain	0.01 GHz < f < 3.9 GHz		-16		dB
		3.9 GHz < f < 12.1 GHz		See note ⁽¹⁾		
SCD11	Differential to common mode conversion gain	f < 8.25 GHz		-45		dB
		8.25 GHz < f < 20 GHz		-35		
t _{R-OUT}	Output rise time	20% to 80%, t _{R-IN} < 40 ps, 25 Ω load, single-ended		25	35	ps
t _{F-OUT}	Output fall time	20% to 80%, t _{F-IN} < 40 ps, 25 Ω load, single-ended		25	35	ps
I _{MOD-MIN}	Minimum modulation current				10	mA
I _{MOD-MAX}	Maximum modulation current	AC Coupled Outputs	70	85		mA
I _{MOD-STEP}	Modulation current step size	10 Bit Register		83		μA
DJ	Deterministic output jitter	EQENA = 0, K28.5 pattern at 11.3 Gbps, 100 mVpp, 600 mVpp, 1200 mVpp differential input voltage		5	10	ps _{p-p}
		EQENA = 1, K28.5 pattern at 11.3 Gbps, maximum equalization with 12" transmission line at the input, 400 mVpp at input to transmission line		7		
RJ	Random output jitter			0.4	0.8	ps _{RMS}
τ _{APC}	APC time constant	C _{APC} = 0.01 μF , I _{PD} = 100 μA , PD coupling ratio, CR = 40 ⁽²⁾		120		μs
		Cross Point Control Range		30%	70%	
T _{OFF}	Transmitter disable time	Rising edge of DIS to I _{BIAS} ≤ 0.1 × I _{BIAS-NOMINAL} ⁽²⁾		0.05	5	μs
T _{ON}	Disable negate time	Falling edge of DIS to I _{BIAS} ≥ 0.9 × I _{BIAS-NOMINAL} ⁽²⁾			1	ms
T _{INIT1}	Power-on to initialize	Power-on to registers ready to be loaded		1	10	ms
T _{INIT2}	Initialize to transmit	Register load STOP command to part ready to transmit valid data ⁽²⁾			2	ms
T _{RESET}	DIS pulse width	Time DIS must be held high to reset part ⁽²⁾	100			ns
T _{FAULT}	Fault assert time	Time from fault condition to FLT high ⁽²⁾			50	μs

(1) Differential Return Gain given by SDD11, SDD22 = $-11.6 + 13.33 \times \log_{10}(f+8.25)$, f expressed in GHz

(2) Assured by simulation over process, supply, and temperature variation.

DETAILED DESCRIPTION

EQUALIZER

The data signal can be applied to an input equalizer by means of the input signal pins DIN+ / DIN-, which provide on-chip differential 100 Ω line-termination. The equalizer is enabled by setting EQENA = 1 (bit 1 of register 0). Equalization of up to 300 mm (12") of microstrip or stripline transmission line on FR4 printed circuit boards can be achieved. The amount of equalization is digitally controlled by the two-wire interface and control logic block, and is dependant on the register settings EQADJ[0...7] (register 6). The equalizer can also be turned off and bypassed by setting EQENA = 0. For details about the equalizer settings, see [Table 12 - Register Functionality](#).

LIMITER

By limiting the output signal of the equalizer to a fixed value, the limiter removes any overshoot after the input equalization and provides the input signal for the output driver.

HIGH-SPEED OUTPUT DRIVER

The modulation current is sunk from the common emitter node of the limiting output driver differential pair by means of a modulation current generator, which is digitally controlled by the 2-wire serial interface.

The collector nodes of the output stages are connected to the output pins MOD+ and MOD–. The laser diode can be AC- or DC-coupled, depending on the required modulation current. To obtain the maximum modulation current of 80 mA, AC coupling is required. The modulation outputs are optimized for driving a 25 Ω load.

MODULATION CURRENT GENERATOR

The modulation current generator provides the current for the current modulator described above. The circuit is digitally controlled by the 2-wire interface block.

A 10-bit control bus, MODC[0...9] (register 2 and register 3), is used to set the desired modulation current.

The modulation current can be disabled by setting the DIS input pin high or setting ENA = 0 (bit 7 of register 0). The modulation current is also disabled in a fault condition if the internal fault detection enable register flag FLTEN is set (bit 3 of register 0).

DC OFFSET CANCELLATION AND CROSS POINT CONTROL

The ONET1101L has DC offset cancellation to compensate for internal offset voltages. The offset cancellation can be disabled by setting OCDIS = 1 (bit 3 of register 1). Disabling the offset cancellation permits the output crossing point to be adjusted from a minimum of 30% to 70% of the output eye diagram. The crossing point can be moved toward the one level by setting CPSGN = 1 (bit 7 of register 7) and it can be moved toward the zero level by setting CPSGN = 0. The shift percentage depends upon the register settings CPADJ[0...6] (register 7) and the cross point adjustment range bits CPRNG[0...1] (register 1). Setting CPRNG1 = 0 and CPRNG0 = 0 results in minimum adjustment (fine) capability and setting CPRNG1 = 1 and CPRNG0 = 1 results in maximum (coarse) adjustment capability.

BIAS CURRENT GENERATION AND APC LOOP

The bias current generation and APC loop are controlled by means of the 2-wire interface. In open loop operation, selected with OLENA = 1 (bit 4 of register 0), the bias current is set directly by the 10-bit control word BIASC[0...9] (register 4 and register 5). In automatic power control mode (select with OLENA = 0), the bias current depends on the register settings BIASC[0...9] and the coupling ratio (CR) between the laser bias current and the photodiode current. $CR = I_{BIAS} / I_{PD}$. If the photodiode anode is connected to the PD pin, set PDPOL = 1 (bit 0 of register 0) and if the photodiode cathode is connected to the PD pin, set PDPOL = 0.

Three photodiode current ranges can be selected by means of the PDRNG[1...0] bits (register 0). The photodiode range should be chosen to keep the laser bias control DAC, BIASC[0...9], close to its range center. This keeps the laser bias current set point resolution high. For details regarding the bias current setting in open- and closed-loop mode, see [Table 12](#).

The ONET1101L has the ability to source or sink the bias current. For the BIAS pin to act as a source set BIASPOL = 1 (bit 2 of register 1) and for the BIAS pin to act as a sink set BIASPOL = 0.

The bias current is monitored using a current mirror with a gain value equal to 0.01 (1 %). By connecting a resistor between MONB and GND, the bias current can be monitored as a voltage across the resistor. A low temperature coefficient precision resistor should be used.

ANALOG REFERENCE

The ONET1101L laser driver is supplied by a single 3.3 V \pm 10% supply voltage connected to the VCC pins. This voltage is referenced to ground (GND).

On-chip bandgap voltage circuitry generates a reference voltage, independent of the supply voltage, from which all other internally required voltages and bias currents are derived.

An external zero temperature coefficient resistor must be connected from the RZTC pin of the device to ground (GND). This resistor is used to generate a precise, zero TC current, which is required as a reference current for the on-chip DACs.

POWER-ON RESET

The ONET1101L has power-on reset circuitry that ensures all registers are reset to zero during startup. After the power-on to initialize time (t_{INIT1}), the internal registers are ready to load. The part is ready to transmit data after the initialize to transmit time (t_{INIT2}), assuming that the chip enable bit ENA is set to 1 and the disable pin DIS is low.

The ONET1101L can be disabled using the ENA control register bit or the disable pin DIS. In both cases the internal registers are not reset. After the disable pin DIS is set low or the enable bit ENA is set back to 1, the part returns to its prior output settings.

2-WIRE INTERFACE AND CONTROL LOGIC

The ONET1101L uses a 2-wire serial interface for digital control. The two circuit inputs, SDA and SCK, are driven, respectively, by the serial data and serial clock from a microprocessor, for example. For driving these inputs, TI recommends an open drain output.

The 2-wire interface provides write access to the internal memory map to modify control registers and read access to read out the control signals. The ONET1101L is a slave device only, which means that it cannot initiate a transmission itself; it always relies on the availability of the SCK signal for the duration of the transmission. The master device provides the clock signal plus the START and STOP commands. The protocol for a data transmission is:

1. START command
2. 7-bit slave address (0001000) followed by an eighth bit which is the data direction bit (R/W). A zero indicates a WRITE and a 1 indicates a READ.
3. 8-bit register address
4. 8-bit register data word
5. STOP command

Regarding timing, the ONET1101L is I²C compatible. A typical timing diagram, shown in [Figure 2](#) and [Figure 3](#), describes a complete data transfer. [Table 1](#) provides definitions of parameters for the [Figure 2](#), I²C Timing Diagram.

Bus Idle: Both SDA and SCK lines remain HIGH

Start Data Transfer: A change in the state of the SDA line, from HIGH to LOW, while the SCK line is HIGH, defines a START condition (S). Each data transfer begins with a START condition.

Stop Data Transfer: A change in the state of the SDA line from LOW to HIGH while the SCK line is HIGH defines a STOP condition (P). Each data transfer ends with a STOP condition; however, if the master still wishes to communicate on the bus, it can generate a repeated START condition and address another slave without first generating a STOP condition.

Data Transfer: Only one data byte can be transferred between a START and a STOP condition. The receiver acknowledges the transfer of data.

Acknowledge: Each receiving device, when addressed, is obliged to generate an acknowledgment bit. The transmitter releases the SDA line and a device that acknowledges, must pull down the SDA line during the acknowledge clock pulse simultaneously so the SDA line is stable LOW during the HIGH period of the acknowledge clock pulse. Set-up and hold times must be taken into account. When a slave-receiver fails to acknowledge the slave address, the data line must be left HIGH by the slave. The master can generate a STOP condition to prevent the transfer. If the slave-receiver does acknowledge the slave address but some time later in the transfer cannot receive any more data bytes, the master must cancel the transfer. This is indicated by the slave generating the not acknowledge on the first following byte. The slave leaves the data line HIGH and the master generates the STOP condition.

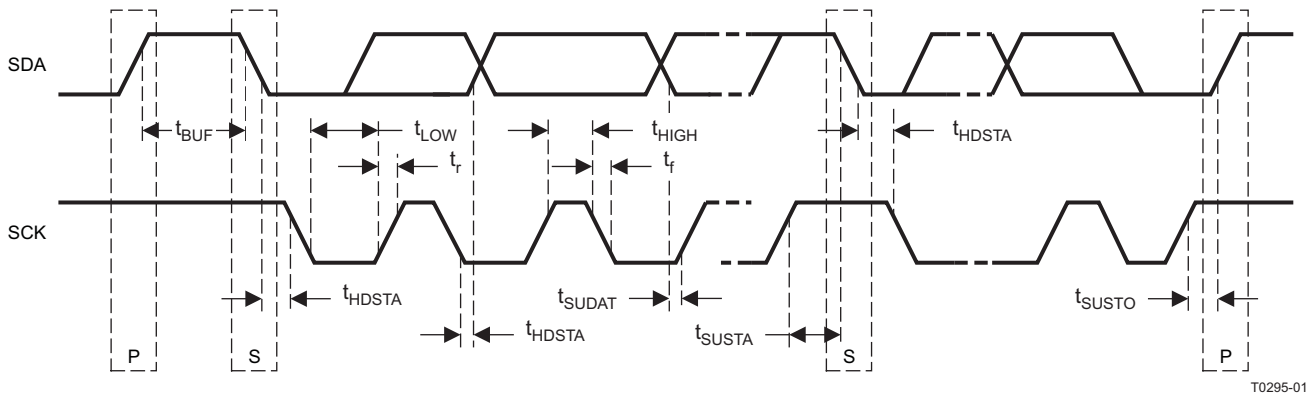

Figure 2. I²C Timing Diagram

Table 1. Timing Diagram Definitions

PARAMETER		MIN	MAX	UNIT
f_{SCK}	SCK clock frequency		400	kHz
t_{BUF}	Bus free time between START and STOP conditions	1.3		μ s
t_{HDSTA}	Hold time after repeated START condition. After this period, the first clock pulse is generated	0.6		μ s
t_{LOW}	Low period of the SCK clock	1.3		μ s
t_{HIGH}	High period of the SCK clock	0.6		μ s
t_{SUSTA}	Setup time for a repeated START condition	0.6		μ s
t_{HDDAT}	Data HOLD time	0		μ s
t_{SUDAT}	Data setup time	100		ns
t_R	Rise time of both SDA and SCK signals		300	ns
t_F	Fall time of both SDA and SCK signals		300	ns
t_{SUSTO}	Setup time for STOP condition	0.6		μ s

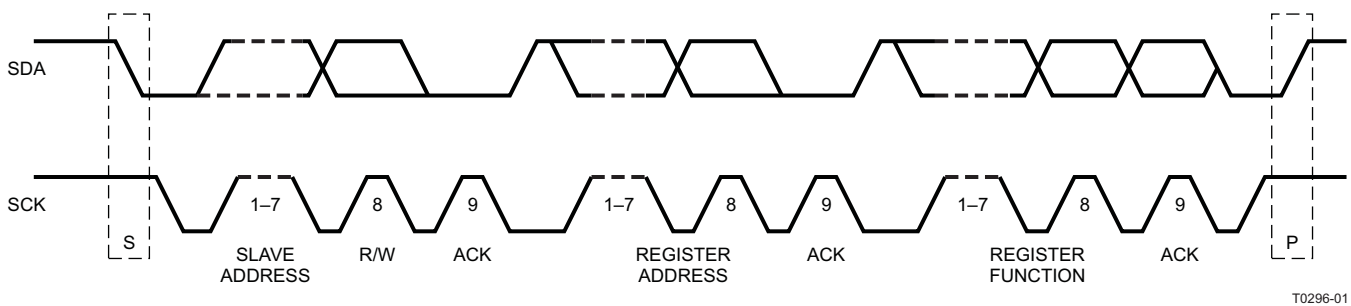

Figure 3. I²C Data Transfer

REGISTER MAPPING

The register mapping for register addresses 0 (0x00) through 9 (0x09) are shown in [Table 2](#) through [Table 11](#). [Table 12](#) describes the circuit functionality based on the register settings.

Table 2. Register 0 (0x00) Mapping – Control Settings

register address 0 (0x00)							
bit 7	bit 6	bit 5	bit 4	bit 3	bit 2	bit 1	bit 0
ENA	PDRNG1	PDRNG0	OLENA	FLTEN	POL	EQENA	PDPOL

Table 3. Register 1 (0x01) Mapping – Control Settings

register address 1 (0x01)							
bit 7	bit 6	bit 5	bit4	bit 3	bit 2	bit 1	bit 0
–	–	–	–	OCDIS	BIASPOL	CPRNG1	CPRNG0

Table 4. Register 2 (0x02) Mapping – Modulation Current

register address 2 (0x02)							
bit 7	bit 6	bit 5	bit4	bit 3	bit 2	bit 1	bit 0
–	–	–	–	–	–	MODC1	MODC0

Table 5. Register 3 (0x03) Mapping – Modulation Current

register address 3 (0x03)							
bit 7	bit 6	bit 5	bit4	bit 3	bit 2	bit 1	bit 0
MODC9	MODC8	MODC7	MODC6	MODC5	MODC4	MODC3	MODC2

Table 6. Register 4 (0x04) Mapping – Bias Current

register address 4 (0x04)							
bit 7	bit 6	bit 5	bit4	bit 3	bit 2	bit 1	bit 0
–	–	–	–	–	–	BIASC1	BIASC0

Table 7. Register 5 (0x05) Mapping – Bias Current

register address 5 (0x05)							
bit 7	bit 6	bit 5	bit4	bit 3	bit 2	bit 1	bit 0
BIASC9	BIASC8	BIASC7	BIASC6	BIASC5	BIASC4	BIASC3	BIASC2

Table 8. Register 6 (0x06) Mapping – Equalizer Adjust

register address 6 (0x06)							
bit 7	bit 6	bit 5	bit4	bit 3	bit 2	bit 1	bit 0
EQADJ7	EQADJ6	EQADJ5	EQADJ4	EQADJ3	EQADJ2	EQADJ1	EQADJ0

Table 9. Register 7 (0x07) Mapping – Cross Point Adjust

register address 7 (0x07)							
bit 7	bit 6	bit 5	bit4	bit 3	bit 2	bit 1	bit 0
CPSGN	CPADJ6	CPADJ5	CPADJ4	CPADJ3	CPADJ2	CPADJ1	CPADJ0

Table 10. Register 8 (0x08) Mapping – Limiter Bias Current Adjust

register address 8 (0x08)							
bit 7	bit 6	bit 5	bit4	bit 3	bit 2	bit 1	bit 0
–	–	–	–	LIMCSGN	LIMC2	LIMC1	LIMC0

Table 11. Register 9 (0x09) Mapping – High Current Enable

register address 9 (0x09)							
bit 7	bit 6	bit 5	bit4	bit 3	bit 2	bit 1	bit 0
–	–	–	–	–	–	–	HMCENA

Table 12. Register Functionality

SYMBOL	REGISTER BIT	FUNCTION
ENA	Enable bit 7	Enable chip bit 1 = chip enabled. Can be toggled low to reset a fault condition. 0 = chip disabled
PDRNG1 PDRNG0	Photodiode current range bit 6 Photodiode current range bit 5	Photodiode current range bits 1X: up to 3080 μ A / 3 μ A resolution 01: up to 1540 μ A / 1.5 μ A resolution 00: up to 770 μ A / 0.75 μ A resolution
OLENA	Open loop enable bit 4	Open loop enable bit 1 = open loop bias current control 0 = closed loop bias current control
FLTEN	Fault detection enable bit 3	Fault detection enable bit 1 = fault detection on 0 = fault detection off
POL	Output polarity switch bit 2	Output polarity switch bit 1: pins 20 and 21 = MOD– and pins 22 and 23 = MOD+ 0: pins 20 and 21 = MOD+ and pins 22 and 23 = MOD–
EQENA	Equalizer enable bit 1	Equalizer enable bit 1 = equalizer enabled 0 = equalizer disabled
PDPOL	Photodiode polarity bit 0	Photodiode polarity bit 1 = photodiode cathode connected to V_{CC} 0 = photodiode anode connected to GND
OCDIS	Offset cancellation disable bit 3	Offset cancellation disable bit 1 = DC offset cancellation is disabled and cross point adjust is enabled 0 = DC offset cancellation is enabled and cross point adjust is disabled
BIASPOL	Bias current polarity bit 2	Bias current polarity bit 1 = Bias pin sources current 0 = Bias pin sinks current
CPRNG1 CPRNG0	Cross point range bit 1 Cross point range bit 0	Cross point adjustment range bits: Minimum adjustment range for 00 Maximum adjustment range for 11
MODC9	Modulation current bit 9 (MSB)	Modulation current setting Modulation current: 85 mA / 83 μ A steps
MODC8	Modulation current bit 8	
MODC7	Modulation current bit 7	
MODC6	Modulation current bit 6	
MODC5	Modulation current bit 5	
MODC4	Modulation current bit 4	
MODC3	Modulation current bit 3	
MODC2	Modulation current bit 2	
MODC1	Modulation current bit 1	
MODC0	Modulation current bit 0 (LSB)	
BIASC9	Bias current bit 9 (MSB)	Closed loop (APC) Coupling ratio $CR = I_{BIAS} / I_{PD}$, $BIASC = 0...1023$, $I_{BIAS} \leq 100$ mA PDRNG = 00 (see Photodiode current range bits); $I_{BIAS} = 0.75 \mu A \times CR \times BIASC$ PDRNG = 01 (see Photodiode current range bits); $I_{BIAS} = 1.5 \mu A \times CR \times BIASC$ PDRNG = 1X (see Photodiode current range bits); $I_{BIAS} = 3 \mu A \times CR \times BIASC$ Open loop $I_{BIAS} = 98 \mu A \times BIASC$
BIASC8	Bias current bit 8	
BIASC7	Bias current bit 7	
BIASC6	Bias current bit 6	
BIASC5	Bias current bit 5	
BIASC4	Bias current bit 4	
BIASC3	Bias current bit 3	
BIASC2	Bias current bit 2	
BIASC1	Bias current bit 1	
BIASC0	Bias current bit 0 (LSB)	

Table 12. Register Functionality (continued)

SYMBOL	REGISTER BIT	FUNCTION
EQADJ7	Equalizer adjustment bit 7 (MSB)	Equalizer adjustment setting EQENA = 0 (see Equalizer Enable Bit) Equalizer is turned off and bypassed EQENA = 1 (see Equalizer Enable Bit) Maximum equalization for 00000000 Minimum equalization for 11111111
EQADJ6	Equalizer adjustment bit 6	
EQADJ5	Equalizer adjustment bit 5	
EQADJ4	Equalizer adjustment bit 4	
EQADJ3	Equalizer adjustment bit 3	
EQADJ2	Equalizer adjustment bit 2	
EQADJ1	Equalizer adjustment bit 1	
EQADJ0	Equalizer adjustment bit 0 (LSB)	
CPSGN	Eye crossing sign bit 7	Eye cross-point adjustment setting CPSGN = 1 (positive shift) Maximum shift for 11111111 Minimum shift for 00000000 CPSGN = 0 (negative shift) Maximum shift for 11111111 Minimum shift for 00000000
CPADJ6	Eye crossing adjustment bit 6 (MSB)	
CPADJ5	Eye crossing adjustment bit 5	
CPADJ4	Eye crossing adjustment bit 4	
CPADJ3	Eye crossing adjustment bit 3	
CPADJ2	Eye crossing adjustment bit 2	
CPADJ1	Eye crossing adjustment bit 1	
CPADJ0	Eye crossing adjustment bit 0 (LSB)	
LIMCSGN	Limiter current sign bit 3	Limiter bias current setting LIMCSGN = 1: decrease current LIMCSGN = 0: increase current No change for 000 and maximum change for 111
LIMC2	Limiter current bit 2 (MSB)	
LIMC1	Limiter current bit 1	
LIMC0	Limiter current bit 0 (LSB)	
HMCENA	High modulation current enable bit 0	High modulation current enable bit 1 = high modulation current capability up to 100 mA 0 = modulation current capability up to 80 mA

LASER SAFETY FEATURES AND FAULT RECOVERY PROCEDURE

The ONET1101L provides built-in laser safety features and can detect these fault conditions:

- Voltage at MONB exceeds the voltage at RZTC (1.16 V)
- Photodiode current exceeds 150% of its set value
- Bias control DAC drops in value by more than 50% in one step

If one or more fault conditions happen and the fault enable bit FLTEN is set to 1, the ONET1101L responds by:

- Setting the bias current to zero.
- Setting the modulation current to zero.
- Asserting and latching the FLT pin.

ONET1101L Fault recovery happens using this procedure:

1. The disable pin DIS or the internal enable control bit ENA are toggled for at least the fault latch reset time.
2. The FLT pin de-asserts while the disable pin DIS is asserted or the enable bit ENA is de-asserted.
3. If the fault condition is no longer present, the part returns to normal operation with its prior output settings after the disable negate time.
4. If the fault condition is still present, FLT re-asserts once DIS is set to a low level and the part does not return to normal operation.

TYPICAL OPERATION CHARACTERISTICS

Typical operating condition is at $V_{CC} = 3.3\text{ V}$, $T_A = 25^\circ\text{C}$, $I_{BIAS} = 40\text{ mA}$, $I_{MOD} = 40\text{ mA}$, $V_{IN} = 600\text{ mVpp}$ (unless otherwise noted).

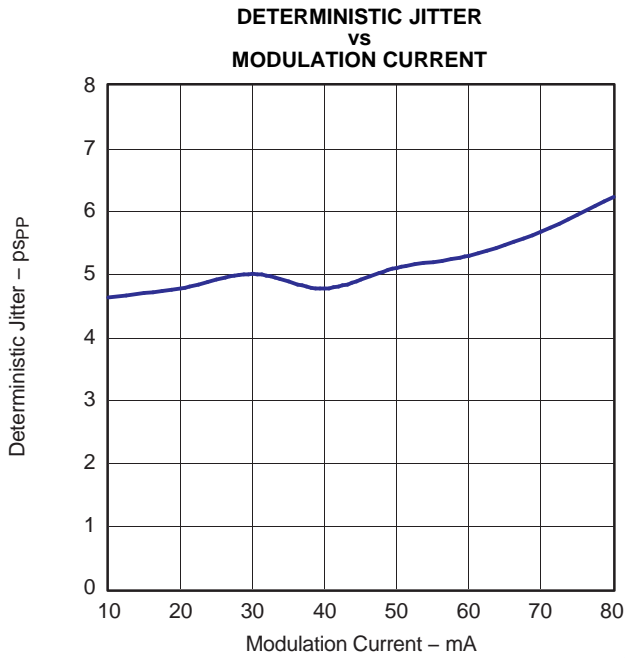

Figure 4.

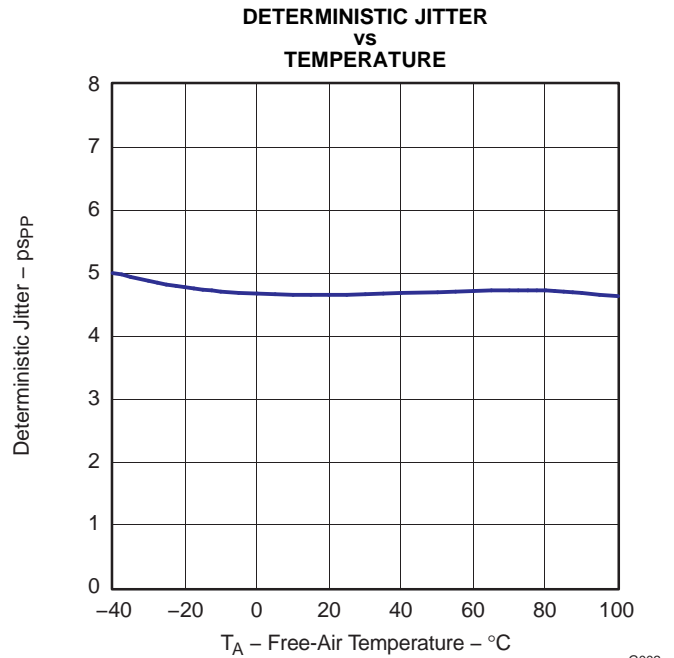

Figure 5.

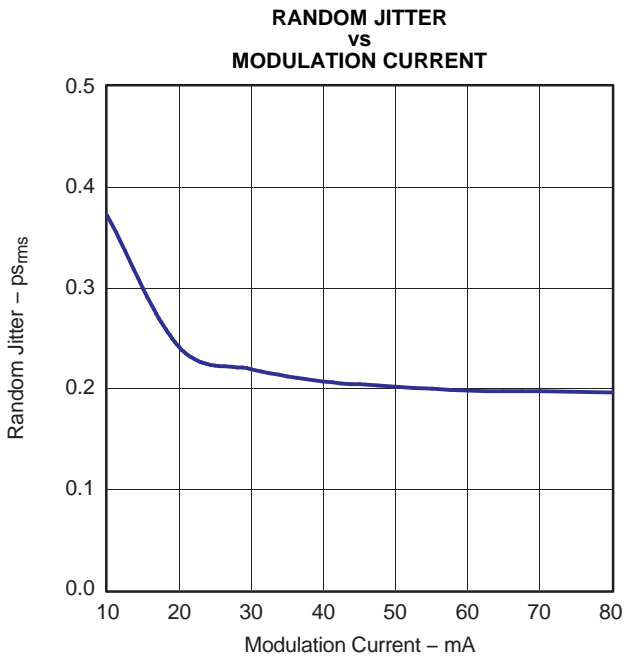

Figure 6.

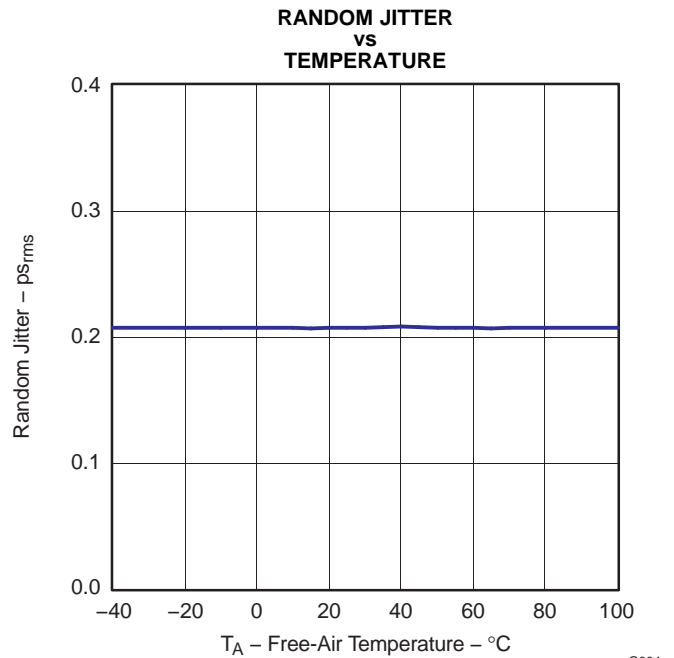

Figure 7.

TYPICAL OPERATION CHARACTERISTICS (continued)

Typical operating condition is at $V_{CC} = 3.3\text{ V}$, $T_A = 25^\circ\text{C}$, $I_{BIAS} = 40\text{ mA}$, $I_{MOD} = 40\text{ mA}$, $V_{IN} = 600\text{ mVpp}$ (unless otherwise noted).

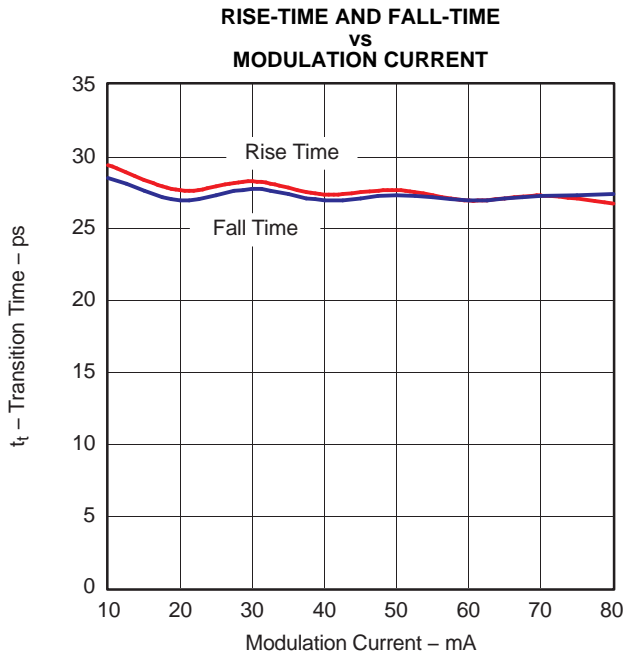

Figure 8.

G005

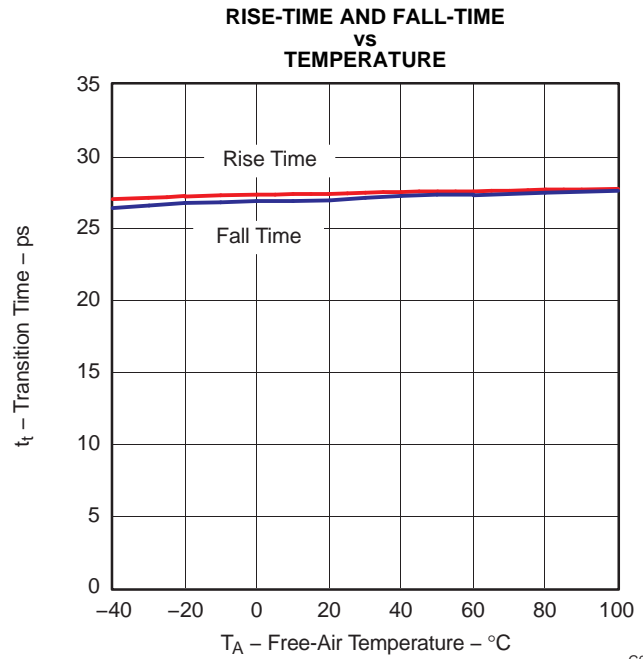

Figure 9.

G006

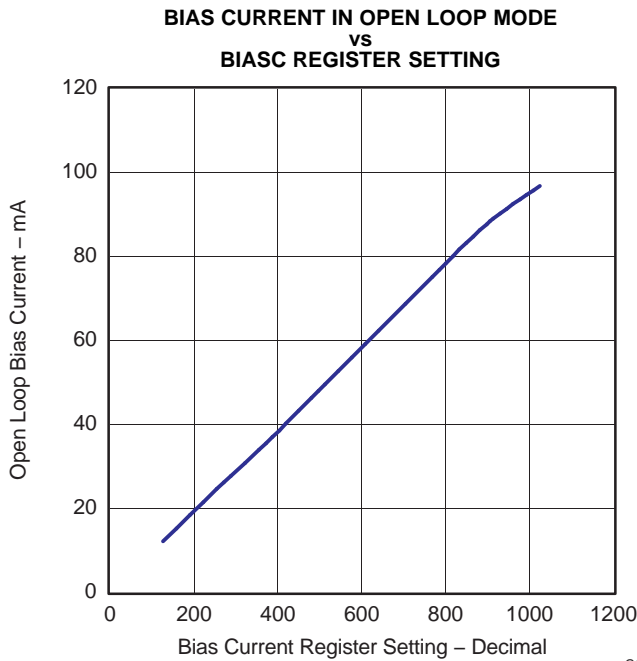

Figure 10.

G007

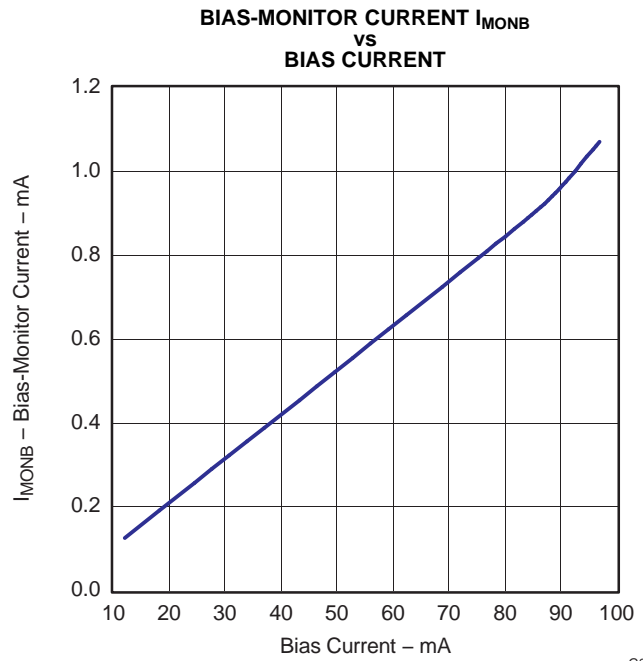

Figure 11.

G008

TYPICAL OPERATION CHARACTERISTICS (continued)

Typical operating condition is at $V_{CC} = 3.3\text{ V}$, $T_A = 25^\circ\text{C}$, $I_{BIAS} = 40\text{ mA}$, $I_{MOD} = 40\text{ mA}$, $V_{IN} = 600\text{ mVpp}$ (unless otherwise noted).

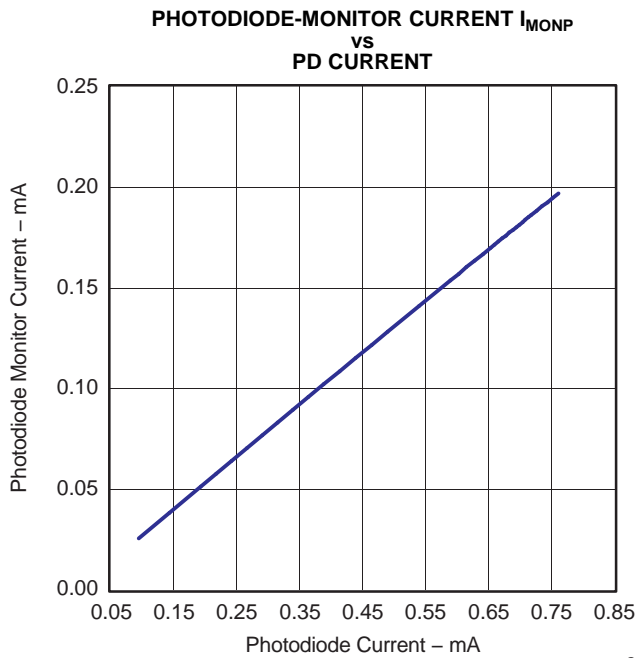

Figure 12.

G009

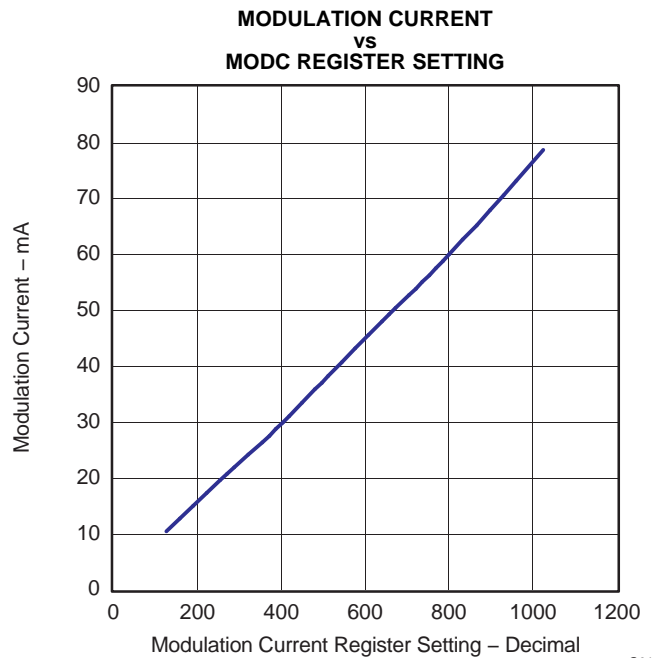

Figure 13.

G010

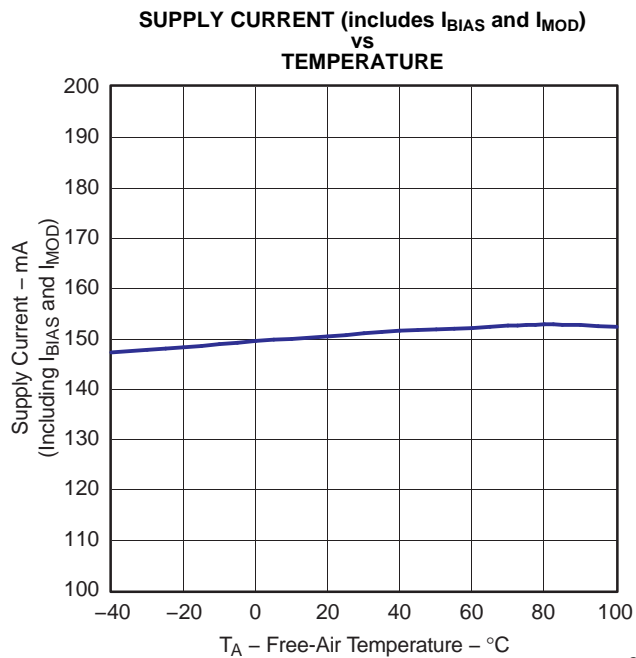

Figure 14.

G011

EYE-DIAGRAM AT 11.3 GBPS, PRBS-31 PATTERN
 $I_{MOD} = 20\text{ mA}$, $EQENA = 0$

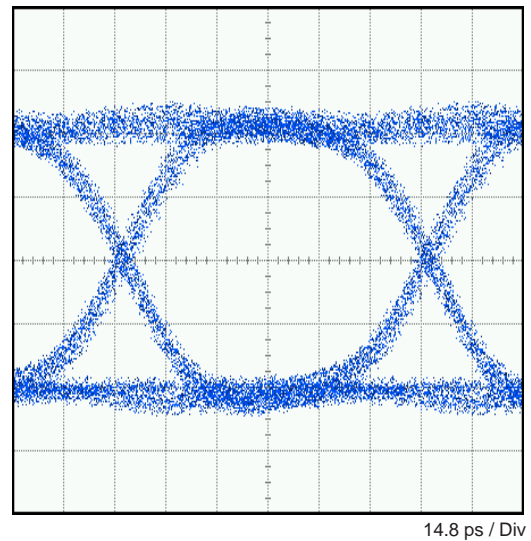

Figure 15.

G012

TYPICAL OPERATION CHARACTERISTICS (continued)

Typical operating condition is at $V_{CC} = 3.3\text{ V}$, $T_A = 25^\circ\text{C}$, $I_{BIAS} = 40\text{ mA}$, $I_{MOD} = 40\text{ mA}$, $V_{IN} = 600\text{ mVpp}$ (unless otherwise noted).

EYE-DIAGRAM AT 11.3GBPS, PRBS-31 PATTERN
 $I_{MOD} = 40\text{ mA}$, $EQENA = 0$

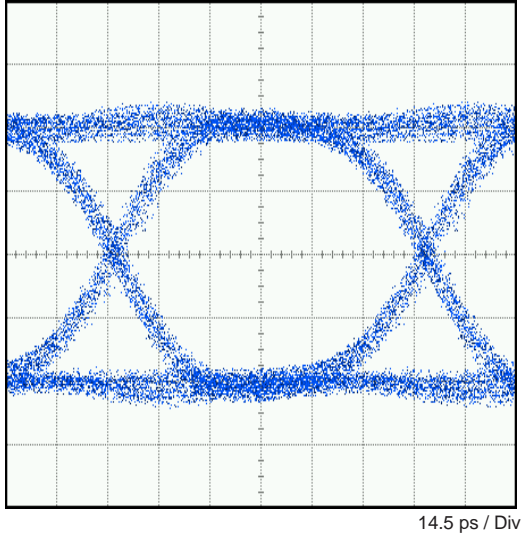

G013

Figure 16.

EYE-DIAGRAM AT 11.3GBPS, PRBS-31 PATTERN
 $I_{MOD} = 60\text{ mA}$, $EQENA = 0$

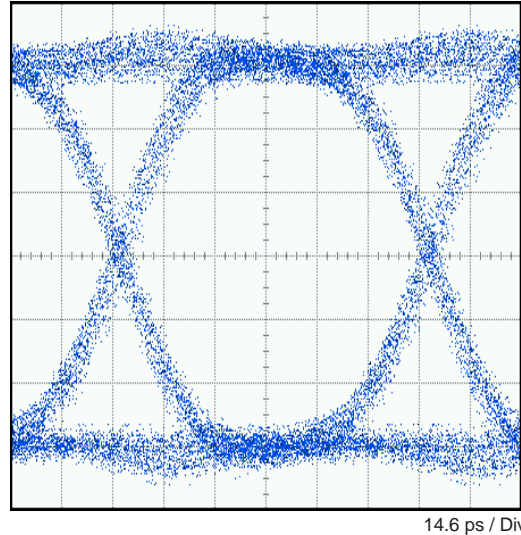

G014

Figure 17.

EYE-DIAGRAM AT 11.3GBPS, PRBS-31 PATTERN
 $I_{MOD} = 40\text{ mA}$, $EQENA = 1$
12" OF FR4 AT INPUTS

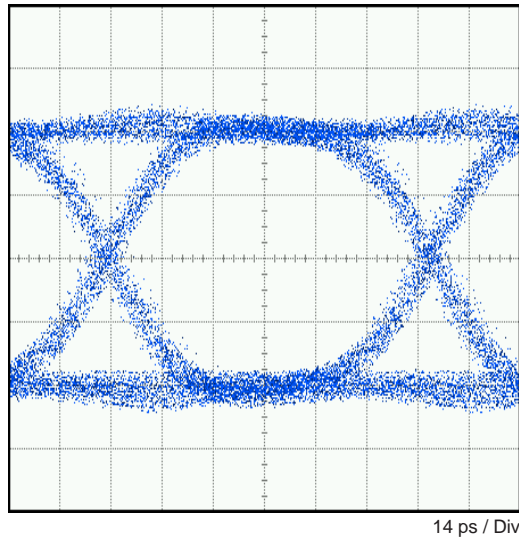

G015

Figure 18.

APPLICATION INFORMATION

Figure 19 and Figure 20 show typical application circuits using the ONET1101L with a laser biased to VCC (BIAS pin sink) and driven differentially or single-ended. The laser driver is controlled using the 2-wire interface SDA/SCK by a microcontroller. In a typical application, the FLT, MONB, and MONP outputs are also connected to the microcontroller for transceiver management purposes.

The component values in Figure 19 and Figure 20 are typical examples and may be varied according to the intended application.

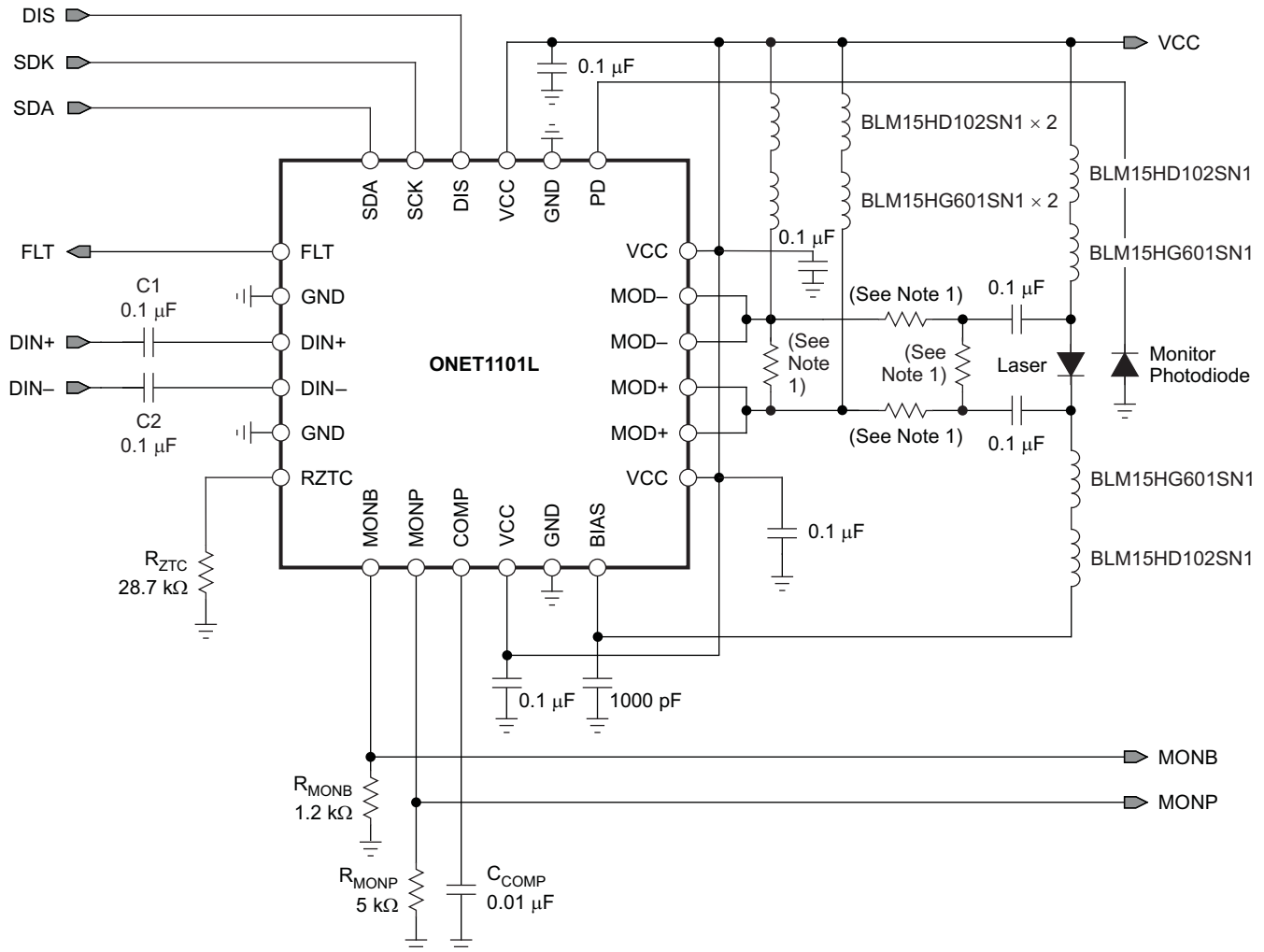

S0319-01

(1) Resistor values depend on the TOSA diode used.

Figure 19. AC Coupled Differential Drive

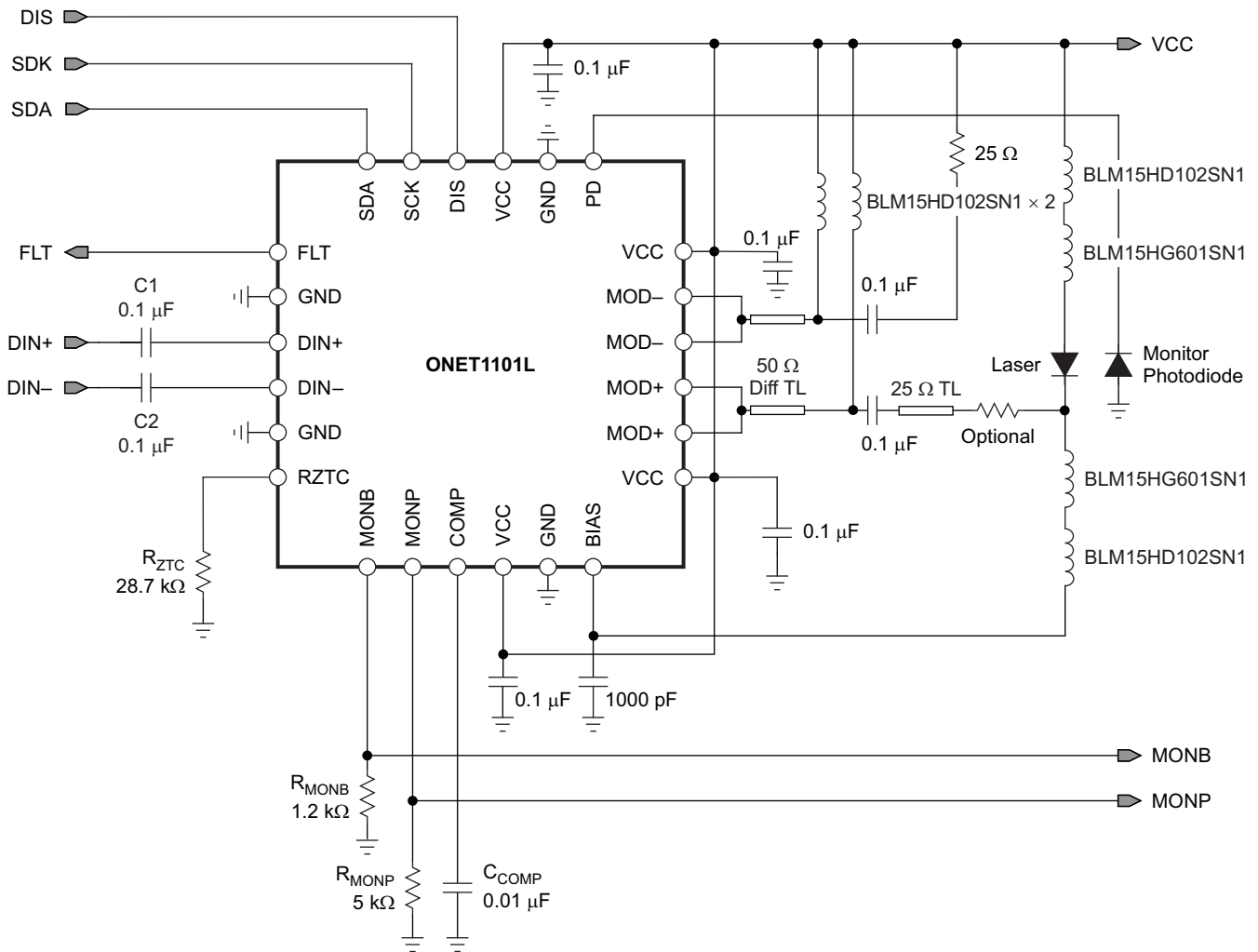

S0320-01

Figure 20. AC Coupled Single-Ended Drive

CALCULATING POWER CONSUMPTION

The power dissipation is different, depending if the BIAS pin is sourcing or sinking current. Lower power dissipation in the ONET1101L can be achieved if the BIAS pin sinks the bias current because the BIAS pin compliance voltage is typically less than 1 V.

The power dissipation is calculated as:

$$P = V_{CC} \times (I_{VCC} + I_{MOD}) + (V_{BIAS} \times I_{BIAS})$$

Where:

V_{CC} is the power supply voltage

I_{VCC} is the supply current excluding modulation and bias current

I_{MOD} is the modulation current

V_{BIAS} is the voltage at the BIAS pin

I_{BIAS} is the bias current

LAYOUT GUIDELINES

For optimum performance, use 50 Ω transmission lines (100 Ω differential) for connecting the signal source to the DIN+ and DIN– pins and 25 Ω transmission lines (50 Ω differential) for connecting the modulation current outputs, MOD+ and MOD–, to the laser. The length of the transmission lines should be kept as short as possible to reduce loss and pattern-dependent jitter. It is recommended to assemble the series matching resistor as close as possible to the TOSA diode, if required.

PACKAGING INFORMATION

Orderable Device	Status ⁽¹⁾	Package Type	Package Drawing	Pins	Package Qty	Eco Plan ⁽²⁾	Lead/Ball Finish	MSL Peak Temp ⁽³⁾
ONET1101LRGER	ACTIVE	VQFN	RGE	24	3000	Green (RoHS & no Sb/Br)	CU NIPDAU	Level-2-260C-1 YEAR
ONET1101LRGERG4	ACTIVE	VQFN	RGE	24	3000	Green (RoHS & no Sb/Br)	CU NIPDAU	Level-2-260C-1 YEAR
ONET1101LRGET	ACTIVE	VQFN	RGE	24	250	Green (RoHS & no Sb/Br)	CU NIPDAU	Level-2-260C-1 YEAR
ONET1101LRGETG4	ACTIVE	VQFN	RGE	24	250	Green (RoHS & no Sb/Br)	CU NIPDAU	Level-2-260C-1 YEAR

⁽¹⁾ The marketing status values are defined as follows:

ACTIVE: Product device recommended for new designs.

LIFEBUY: TI has announced that the device will be discontinued, and a lifetime-buy period is in effect.

NRND: Not recommended for new designs. Device is in production to support existing customers, but TI does not recommend using this part in a new design.

PREVIEW: Device has been announced but is not in production. Samples may or may not be available.

OBSOLETE: TI has discontinued the production of the device.

⁽²⁾ Eco Plan - The planned eco-friendly classification: Pb-Free (RoHS), Pb-Free (RoHS Exempt), or Green (RoHS & no Sb/Br) - please check <http://www.ti.com/productcontent> for the latest availability information and additional product content details.

TBD: The Pb-Free/Green conversion plan has not been defined.

Pb-Free (RoHS): TI's terms "Lead-Free" or "Pb-Free" mean semiconductor products that are compatible with the current RoHS requirements for all 6 substances, including the requirement that lead not exceed 0.1% by weight in homogeneous materials. Where designed to be soldered at high temperatures, TI Pb-Free products are suitable for use in specified lead-free processes.

Pb-Free (RoHS Exempt): This component has a RoHS exemption for either 1) lead-based flip-chip solder bumps used between the die and package, or 2) lead-based die adhesive used between the die and leadframe. The component is otherwise considered Pb-Free (RoHS compatible) as defined above.

Green (RoHS & no Sb/Br): TI defines "Green" to mean Pb-Free (RoHS compatible), and free of Bromine (Br) and Antimony (Sb) based flame retardants (Br or Sb do not exceed 0.1% by weight in homogeneous material)

⁽³⁾ MSL, Peak Temp. -- The Moisture Sensitivity Level rating according to the JEDEC industry standard classifications, and peak solder temperature.

Important Information and Disclaimer:The information provided on this page represents TI's knowledge and belief as of the date that it is provided. TI bases its knowledge and belief on information provided by third parties, and makes no representation or warranty as to the accuracy of such information. Efforts are underway to better integrate information from third parties. TI has taken and continues to take reasonable steps to provide representative and accurate information but may not have conducted destructive testing or chemical analysis on incoming materials and chemicals. TI and TI suppliers consider certain information to be proprietary, and thus CAS numbers and other limited information may not be available for release.

In no event shall TI's liability arising out of such information exceed the total purchase price of the TI part(s) at issue in this document sold by TI to Customer on an annual basis.

MECHANICAL DATA

RGE (S-PVQFN-N24)

PLASTIC QUAD FLATPACK NO-LEAD

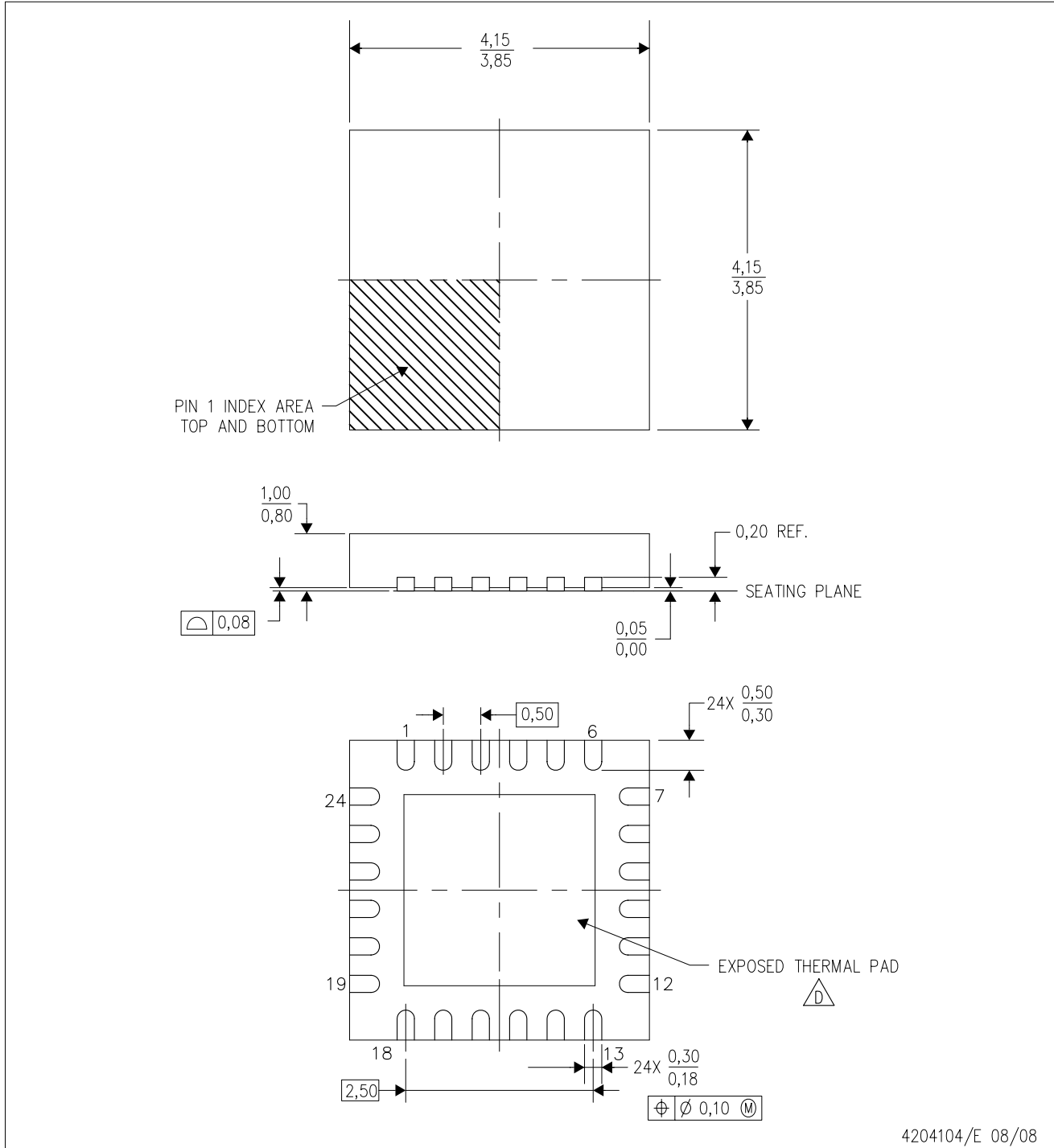

- NOTES:
- A. All linear dimensions are in millimeters. Dimensioning and tolerancing per ASME Y14.5M-1994.
 - B. This drawing is subject to change without notice.
 - C. Quad Flatpack, No-Leads (QFN) package configuration.
 -  The package thermal pad must be soldered to the board for thermal and mechanical performance. See the Product Data Sheet for details regarding the exposed thermal pad dimensions.
 - E. Falls within JEDEC MO-220.

THERMAL INFORMATION

This package incorporates an exposed thermal pad that is designed to be attached directly to an external heatsink. The thermal pad must be soldered directly to the printed circuit board (PCB). After soldering, the PCB can be used as a heatsink. In addition, through the use of thermal vias, the thermal pad can be attached directly to the appropriate copper plane shown in the electrical schematic for the device, or alternatively, can be attached to a special heatsink structure designed into the PCB. This design optimizes the heat transfer from the integrated circuit (IC).

For information on the Quad Flatpack No-Lead (QFN) package and its advantages, refer to Application Report, QFN/SON PCB Attachment, Texas Instruments Literature No. SLUA271. This document is available at www.ti.com.

The exposed thermal pad dimensions for this package are shown in the following illustration.

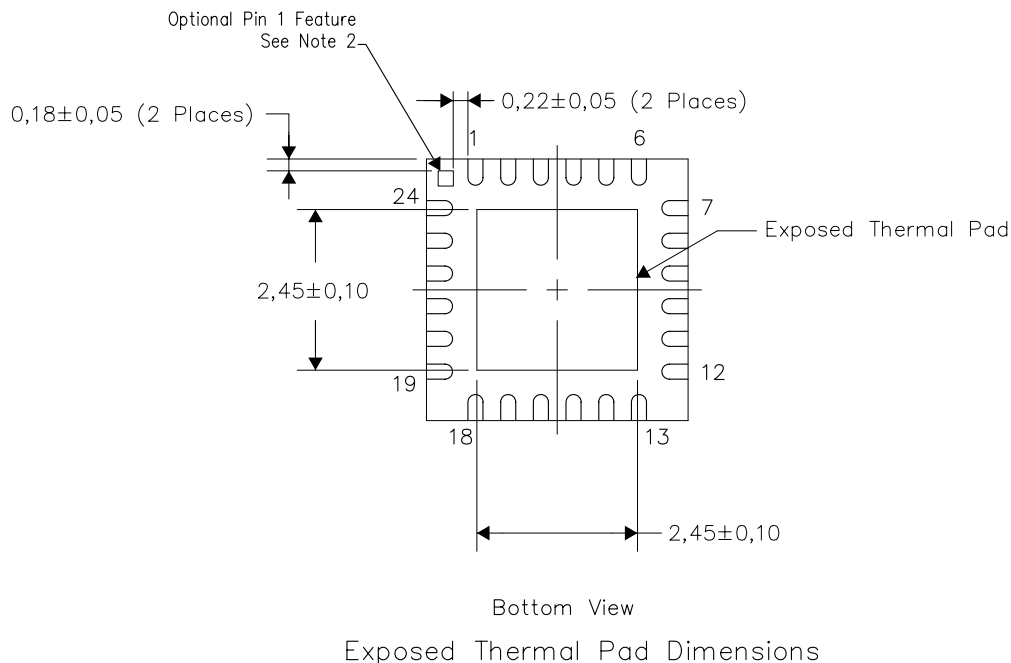

NOTES:

- 1) All linear dimensions are in millimeters
- 2) The Pin 1 Identification mark is an optional feature that may be present on some devices
 In addition, this Pin 1 feature if present is electrically connected to the center thermal pad and therefore should be considered when routing the board layout.

RGE (S-PVQFN-N24)

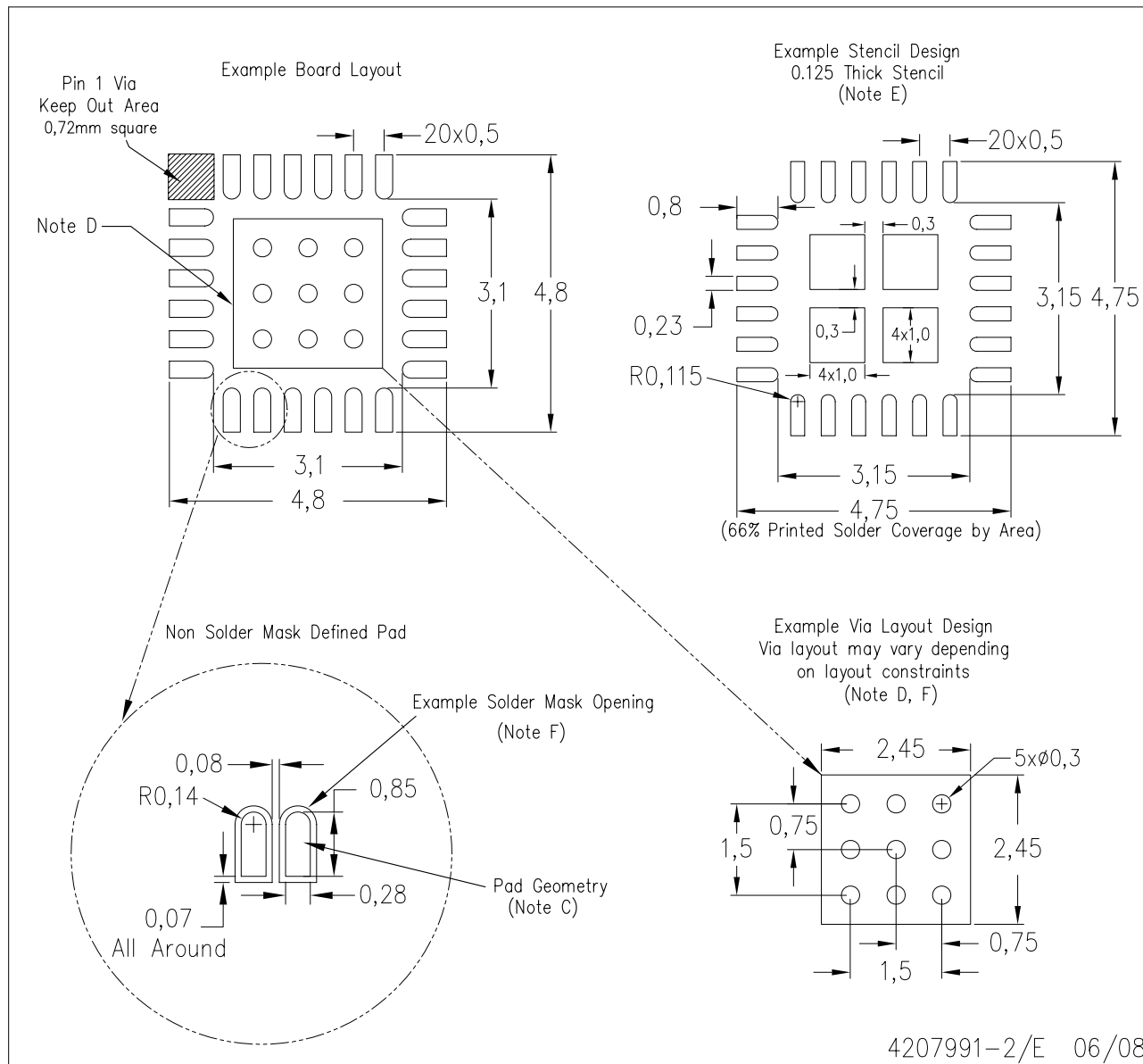

- NOTES:
- A. All linear dimensions are in millimeters.
 - B. This drawing is subject to change without notice.
 - C. Publication IPC-7351 is recommended for alternate designs.
 - D. This package is designed to be soldered to a thermal pad on the board. Refer to Application Note, Quad Flat-Pack Packages, Texas Instruments Literature No. SCBA017, SLUA271, and also the Product Data Sheets for specific thermal information, via requirements, and recommended board layout. These documents are available at www.ti.com <<http://www.ti.com>>.
 - E. Laser cutting apertures with trapezoidal walls and also rounding corners will offer better paste release. Customers should contact their board assembly site for stencil design recommendations. Refer to IPC 7525 for stencil design considerations.
 - F. Customers should contact their board fabrication site for recommended solder mask tolerances and via tenting recommendations for vias placed in the thermal pad.

IMPORTANT NOTICE

Texas Instruments Incorporated and its subsidiaries (TI) reserve the right to make corrections, modifications, enhancements, improvements, and other changes to its products and services at any time and to discontinue any product or service without notice. Customers should obtain the latest relevant information before placing orders and should verify that such information is current and complete. All products are sold subject to TI's terms and conditions of sale supplied at the time of order acknowledgment.

TI warrants performance of its hardware products to the specifications applicable at the time of sale in accordance with TI's standard warranty. Testing and other quality control techniques are used to the extent TI deems necessary to support this warranty. Except where mandated by government requirements, testing of all parameters of each product is not necessarily performed.

TI assumes no liability for applications assistance or customer product design. Customers are responsible for their products and applications using TI components. To minimize the risks associated with customer products and applications, customers should provide adequate design and operating safeguards.

TI does not warrant or represent that any license, either express or implied, is granted under any TI patent right, copyright, mask work right, or other TI intellectual property right relating to any combination, machine, or process in which TI products or services are used. Information published by TI regarding third-party products or services does not constitute a license from TI to use such products or services or a warranty or endorsement thereof. Use of such information may require a license from a third party under the patents or other intellectual property of the third party, or a license from TI under the patents or other intellectual property of TI.

Reproduction of TI information in TI data books or data sheets is permissible only if reproduction is without alteration and is accompanied by all associated warranties, conditions, limitations, and notices. Reproduction of this information with alteration is an unfair and deceptive business practice. TI is not responsible or liable for such altered documentation. Information of third parties may be subject to additional restrictions.

Resale of TI products or services with statements different from or beyond the parameters stated by TI for that product or service voids all express and any implied warranties for the associated TI product or service and is an unfair and deceptive business practice. TI is not responsible or liable for any such statements.

TI products are not authorized for use in safety-critical applications (such as life support) where a failure of the TI product would reasonably be expected to cause severe personal injury or death, unless officers of the parties have executed an agreement specifically governing such use. Buyers represent that they have all necessary expertise in the safety and regulatory ramifications of their applications, and acknowledge and agree that they are solely responsible for all legal, regulatory and safety-related requirements concerning their products and any use of TI products in such safety-critical applications, notwithstanding any applications-related information or support that may be provided by TI. Further, Buyers must fully indemnify TI and its representatives against any damages arising out of the use of TI products in such safety-critical applications.

TI products are neither designed nor intended for use in military/aerospace applications or environments unless the TI products are specifically designated by TI as military-grade or "enhanced plastic." Only products designated by TI as military-grade meet military specifications. Buyers acknowledge and agree that any such use of TI products which TI has not designated as military-grade is solely at the Buyer's risk, and that they are solely responsible for compliance with all legal and regulatory requirements in connection with such use.

TI products are neither designed nor intended for use in automotive applications or environments unless the specific TI products are designated by TI as compliant with ISO/TS 16949 requirements. Buyers acknowledge and agree that, if they use any non-designated products in automotive applications, TI will not be responsible for any failure to meet such requirements.

Following are URLs where you can obtain information on other Texas Instruments products and application solutions:

Products

Amplifiers	amplifier.ti.com
Data Converters	dataconverter.ti.com
DSP	dsp.ti.com
Clocks and Timers	www.ti.com/clocks
Interface	interface.ti.com
Logic	logic.ti.com
Power Mgmt	power.ti.com
Microcontrollers	microcontroller.ti.com
RFID	www.ti-rfid.com
RF/IF and ZigBee® Solutions	www.ti.com/lprf

Applications

Audio	www.ti.com/audio
Automotive	www.ti.com/automotive
Broadband	www.ti.com/broadband
Digital Control	www.ti.com/digitalcontrol
Medical	www.ti.com/medical
Military	www.ti.com/military
Optical Networking	www.ti.com/opticalnetwork
Security	www.ti.com/security
Telephony	www.ti.com/telephony
Video & Imaging	www.ti.com/video
Wireless	www.ti.com/wireless

Mailing Address: Texas Instruments, Post Office Box 655303, Dallas, Texas 75265
Copyright © 2008, Texas Instruments Incorporated